

Application Note:

HFAN-2.5.0

Rev 0; 05/04

Single-Ended vs. Differential Methods of Driving a Laser Diode

MAXIM High-Frequency/Fiber Communications Group



Maxim Integrated Products

Single-Ended vs. Differential Methods of Driving a Laser Diode

1 Introduction

A proper interface circuit to connect a driver to a laser diode is essential for an optimized optical transmitter design. In general, the single-ended drive of laser diodes provides a straight forward solution that requires less components and board space. Drawbacks include a comparatively slow output edge-speed and noise added to the transceiver power supply, which will eventually affect the receiver sensitivity. Recent industrial practice has shown that optical transmitters based on differential drives are able to overcome the disadvantages associated with a single-ended drive. The purpose of this application note is to reveal how a differential drive provides a faster edge-speed than a single-ended drive.

2 Circuit Configuration for Single-Ended Drive and Differential Drive

For a single-ended drive, the laser modulation current is applied either to the laser anode (common-cathode laser) or to the laser cathode (common-anode laser). Figure 1 is a simplified schematic for driving a common-anode laser. The modulation current is delivered to the laser cathode through a damping resistor (R_D). The laser anode is directly connected to the power supply, and the laser bias is provided from a driver bias output isolated by a ferrite bead. For a balanced DC and AC loading, the driver complementary output is pulled up to V_{CC} by a parallel network consisting of a ferrite bead and a resistor that matches the equivalence of the laser load and the damping resistor. The RC shunt network (R_F and C_F) provides high-frequency damping. Capacitance C_P (C_{P1} and C_{P2}) at the driver outputs represents a combination of output transistor equivalent capacitance, packaging and board layout parasitic capacitances.

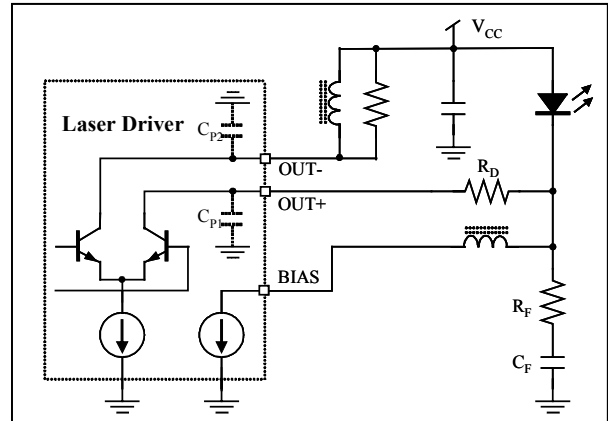

Figure 1. Single-ended Method of Driving a Laser Diode

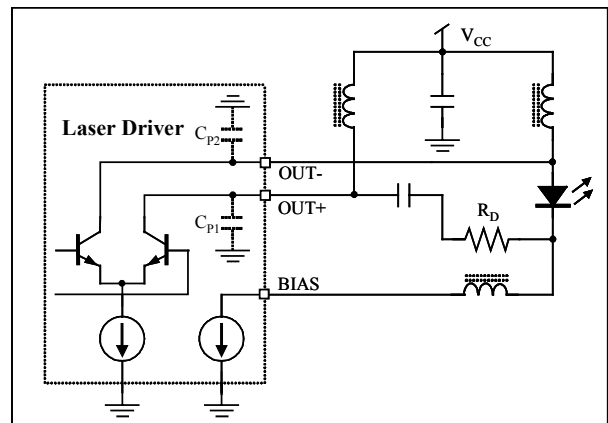

Figure 2. Differential Method of Driving a Laser Diode

Figure 2 shows one example of a differential drive. The laser cathode is AC-coupled to the driver output via a damping resistor (R_D). The driver output is pulled up to V_{CC} through a ferrite bead to provide a DC bias to the output transistor. The shared node of the driver complementary output and the laser diode anode is connected to V_{CC} through a ferrite bead which provides high-frequency isolation from V_{CC} . The laser bias is provided in a similar way as in a single-ended drive configuration. Using the same laser diode and driver, a 2.5Gbps optical transmitter based on differential drive shows more than 20ps improvement in edge-speed than a single-ended drive [1].

3 Charge and Discharge for Single-Ended Drive

The circuit for the single-ended drive in Figure 1 is reorganized in Figure 3. For simplicity, the R_F and C_F compensation network is ignored in the following discussion. During the laser turn-on period, the output transistor T1 provides a sink current to modulate the laser through the damping resistor R_D , and to charge the parasitic capacitor C_{P1} . The full modulation current is only switched to a laser after the C_{P1} charging is completed. Therefore, the transient current that charges this capacitor is primarily responsible for a degraded rising edge-speed.

When the laser is turned off, T1 stops sinking current and the parasitic capacitor C_{P1} is discharged through a series network consisting of the laser diode and the damping resistor. This transient current will slow down the laser-off transition, resulting in a slow tail in optical output. The charge and discharge loop time constant τ_{SE} is estimated as:

$$\tau_{SE} \approx (R_D + R_L) \cdot C_P$$

where R_L is the laser equivalent resistance. The contribution of laser series inductance is ignored in this analysis.

The series resistor R_D is necessary to damp the laser overshoot and ringing caused by laser and assembly inductance. Therefore, reducing the equivalent capacitance at the driver output node is the key factor for achieving a fast optical edge-speed. Figure 4 presents the simulation results of step response. The laser diode is modeled as a 5Ω resistor in parallel with a 1pF capacitor. The damping resistor R_D is chosen as 10Ω . The edge-speed (20%-80%) of the transistors (T1 and T2) used in this test is approximately 25ps . The simulated edge-speed of laser diode output is listed in Table 1. The falling edge is slower than the rising edge.

Table 1. Edge-speed (in ps) and Output Capacitance for a Single-Ended Drive

C_P (C_{P1} & C_{P2})	1pF	2pF	3pF
t_r/t_f (20%-80%)	41/46	53/59	71/78
t_r/t_f (10%-90%)	60/72	83/97	118/125

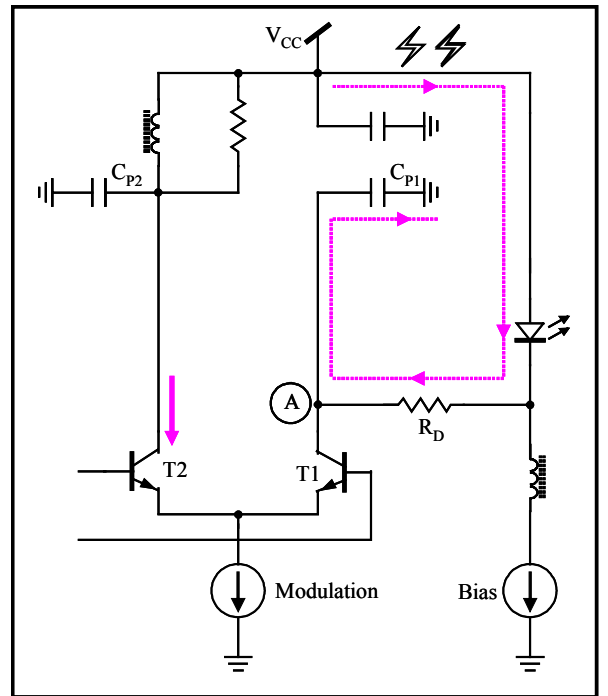
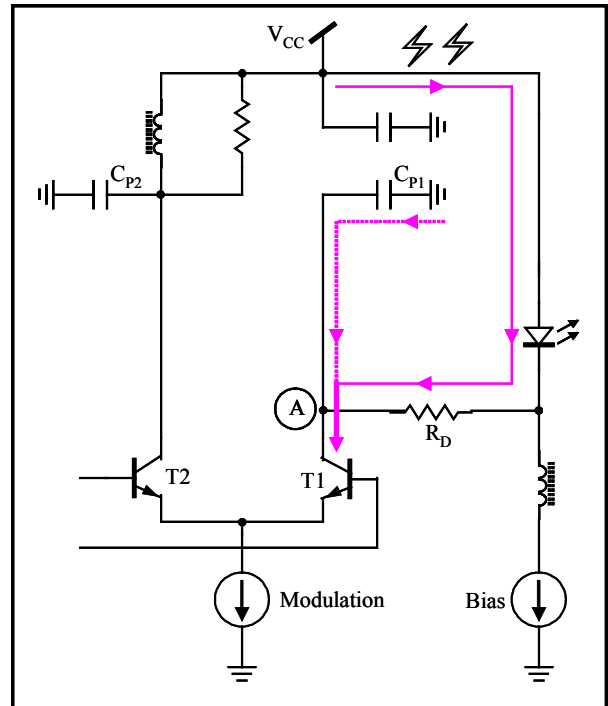

Figure 3. Charge (top) and Discharge (bottom) Loops for a Single-Ended Drive Circuit. (Dotted lines represent a transient current for capacitor charge or discharge)

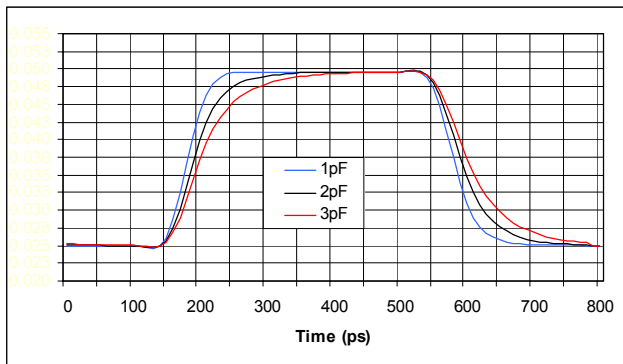

Figure 4. Step Response Simulation for Single-ended Drive

Another disadvantage is that a single-ended drive generates a large transient current flow on the Vcc plane. The transceiver layout and power supply decoupling has to be well designed, otherwise the receiver will pick up noise from the power supply, which eventually may affect the optical receiver sensitivity.

4 Charge and Discharge for Differential Drive

Figure 5 illustrates the current flow for driving a laser diode differentially. When the laser is turned on, the output transistor T1 provides a sink current to charge the parasitic capacitor C_{P1} at the collector of T1, and to modulate the laser through the damping resistor R_D and an AC-coupling capacitor. Since the ferrite beads will force a constant current flow, $i_{CP1} = i_{CP2}$. The charge and discharge process is reversed in a similar loop when the driver current is switched to the complementary side during the laser-off period.

To achieve the same laser modulation current with a differential drive as single-ended drive, the amplitude of the voltage swing over the laser diode and damping resistor should remain the same. This means that the voltage swing at Node A (ΔV_A) for singled-ended drive should equal $(V_A - V_B)$ for the differential drive. Therefore, the voltage swing over the parasitic capacitors C_{P1} and C_{P2} for the differential drive is only half of that for a single-ended drive. The overall effect is that the differential drive leads to a faster signal transmission. The time constant τ_{DF} for laser-on and laser-off is estimated as:

$$\tau_{DF} \approx (R_D + R_L) \cdot \frac{C_{P2}}{1 + C_{P2}/C_{P1}} = \frac{1}{2} (R_D + R_L) \cdot C_P$$

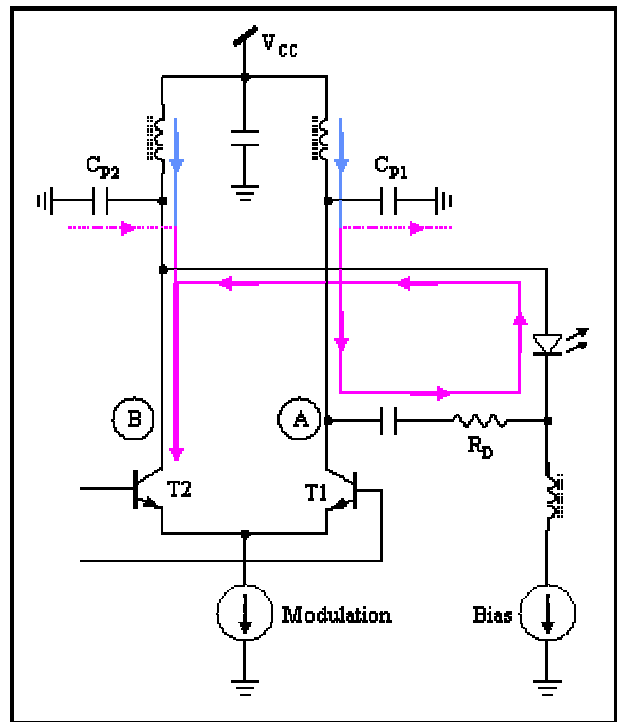
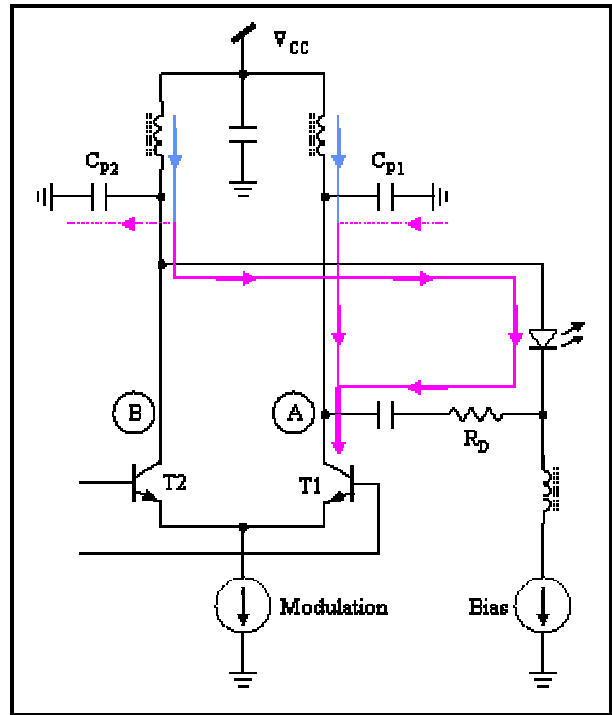

Figure 5. Charge (top) and Discharge (bottom) Loops for a Differential Driving Circuit. (Dotted lines represent a transient current for capacitor charge and discharge. Current through the ferrite bead is assumed constant)

The time constant τ_{DF} for differential drive is about half of the time constant τ_{SE} for a single-ended drive, meaning a fast transmitter edge-speed. The

simulation results of step response are shown in Figure 6 and Table 2. For a 2pF output capacitance the falling edge-speed at 20%-80% and at 10%-90% is improved by 20ps and 43ps respectively.

Table 2. Edge-speed (in ps) and Output Capacitance for Differential Drive

C_p (C_{P1} & C_{P2})	1pF	2pF	3pF
t_r/t_f (20%-80%)	34/34	39/39	45/45
t_r/t_f (10%-90%)	51/50	58/57	71/69

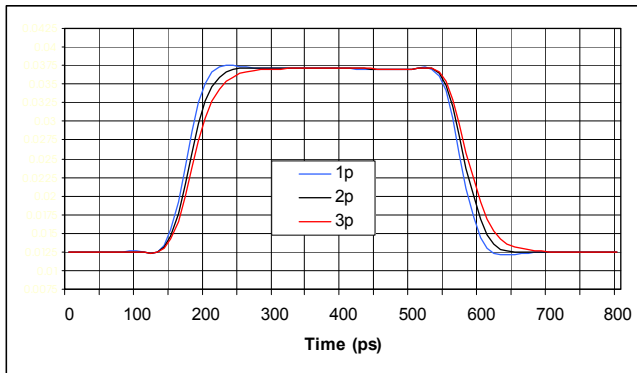

Figure 6. Step Response Simulation for Differential Drive

Because of its symmetrical nature, the differential drive method shows better immunity to capacitive load. The edge-speed degradation from output capacitance is much less than that of a single-ended drive. It also provides a matched rise and fall time, that makes it easy to optimize the transmitter optical eye-diagram. On the other hand, the laser charge and discharge loops include the same external circuit, so it can tolerate more variation and mismatching in board layout, without adding additional noise to the Vcc plane. The disadvantage is that the differential drive approach is based on AC coupling between the driver and the laser diode, which may result in a low-frequency cutoff problem for some applications.

5 Conclusion

This application note shows that the edge-speed of an optical transmitter can be improved by using a differential laser driver configuration. One of the primary benefits of the differential drive is that it can tolerate more capacitance at the output node. This does not mean, however, that output capacitance can be neglected – good high-frequency board layout techniques and other methods of lowering the output capacitance remain important. Also, in real applications, a number of additional factors (not addressed in this application note) must be considered, including: (a) the laser equivalent capacitance that will introduce another pole into the circuit and (b) the laser electrical-to-optical conversion that will slow the edge speeds and cause asymmetry between the rising and falling edges. Because of these factors, high-speed operation will require a relatively fast laser diode along with minimization of the laser package inductance.

Reference

- [1] Application Note: [“MAX3735A Output Configuration Part 3: Differential Drive.”](#) - HFDN-26.2 Maxim Integrated Products, November 2003.